

Precise mass flow metering

deltaflowC was developed to meter air in pipes and channels in a very precise, cost effective manner. deltaflowC features the smallest and fastest multivariable transmitter for metering the mass flow of gases. deltaflowC operates according to the highly precise differential-pressure metering method. Extremely fast sensors for differential pressure, static pressure and temperature, as well as a powerful microcontroller, are integrated in the transducer in an area of just a few cm². The mass flow is metered up to 4000 times per second. The microcontroller processes the values of a mass flow and outputs the mass flow signal, as well as the pressure and temperature signal.

Successfully tested for practical application

The deltaflowC sensor system has proven effective in various applications, including the challenging serial production of combustion engines of trucks and commercial vehicles. Precise and stable in long-term use, even with the strongest pulsations, it precisely records the mass of air supplied to the engine and makes an important contribution to optimum engine control. This technology is now also available for industrial applications. The deltaflowC has 4..20 mA and 0..10 V outputs and can be parameterized in just a few seconds.

Zero maintenance and zero drift

Thanks to modern microcontroller technology, deltaflowC offers an outstanding high zero point stability, a large measuring range, high accuracy and high measurement dynamics.

deltaflowC compensates the influence of pressure and temperature on the measurement and provides the (compensated) mass flow to the user. Unlike other measuring methods, such as thermal mass flow meters, deltaflowC is particularly resistant to condensation and dirt deposits. Together with the automatic zero-point correction, this makes deltaflowC almost zero maintenance and zero drift.

High Accuracy

deltaflowC is available in two accuracy classes. The standard type offers an accuracy of 4%. deltaflowC is also optionally available as calibrated probe with a calibration certificate and an accuracy of 2%.

Typical applications

- Pressurized air
- Building services/heating, ventilation, air-conditioning
- Combustion air regulation
- Monitoring of process air
- Pneumatics
- Exhaust gas metering
- Compressors
- Extraction units
- Exhaust gas volume metering



deltaflow

deltaflowC can be used to meter wide ranges of flow, temperature and pressure. With only one insertion length, it fits almost all pipes or channels. deltaflowC thus has very short delivery times and reduces warehousing costs.

The two analog outputs operate independently of each other and, in addition to mass flow, can also provide pressure or temperature.

Customized devices

OEM / private label versions are available on request. The standard device has 1x 0...10 V + 1x 4...20 mA analog outputs. It can also be fitted, for example, with bus systems, such as CAN and profibus. We will be happy to adapt the deltaflowC to meet (OEM) customer requirements.

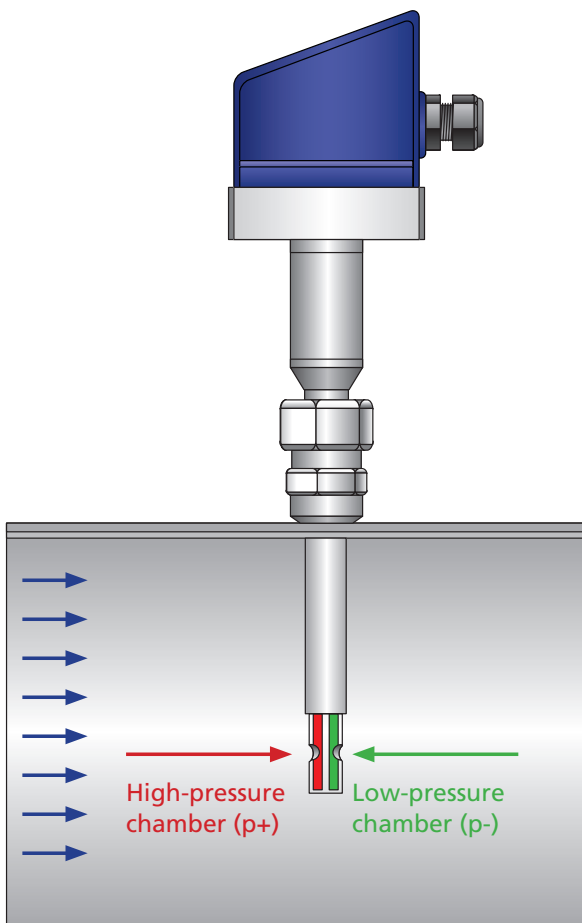

Functional principle of deltaflowC probe

Metering the mass flow according to the differential-pressure method

deltaflowC operates according to the proven and highly precise differential-pressure metering method. The deltaflowC probe has two separate chambers in the special systec Controls probe profile, fitted with apertures in order to read the differential pressure.

The deltaflowC Venturi generates the differential pressure between two holes, one upstream and one in a reduced pipe cross-section.

The flow of the medium creates a pressure difference between the two measurement holes of the probe or venturi: In the aperture, facing the direction of flow a higher pressure ($p+$) and in the aperture facing away from the direction of flow a lower pressure ($p-$).

A differential pressure proportional to the flow is generated in the two differential pressure outlets; this is recorded via the integrated differential pressure transmitter. In parallel, thanks to the integrated pressure and temperature sensors the current density of the medium is calculated and finally, together with the pipe cross-section, the mass flow is determined and transmitted as electrical signal to the control unit.

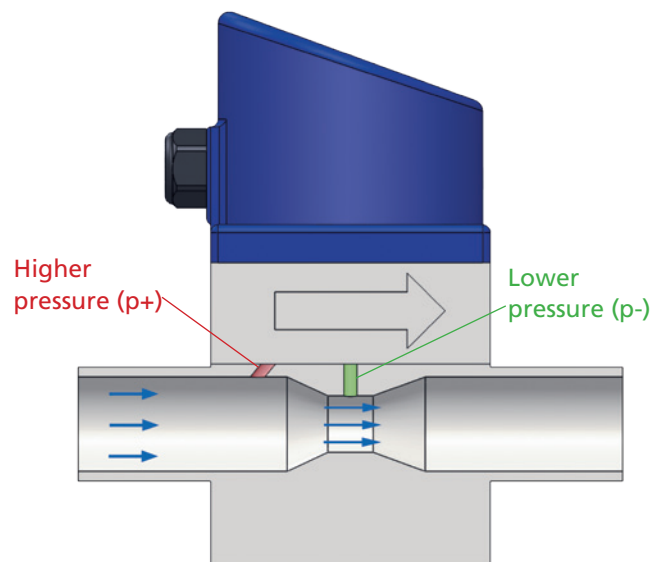

Functional principle of deltaflowC venturi

deltaflowC

Easy to mount and parameterize

With smaller pipes (from DN 20), deltaflow is used across the entire inner diameter of the pipe. With larger pipes, up to DN 6000 and larger, the insertion depth is 100 mm. The flow calculation always takes account of the different positions of the dp tapping, which vary from one application to another. This guarantees metering accuracy for all pipe sizes. Significantly, the user does not have to worry about correct positioning; there are virtually no "installation errors" with deltaflowC.

The deltaflowC probe is delivered with a cutting ring stud as standard. The transducer has 4..20 mA and 0..10 V outputs and can be easily parameterized in just a few seconds using only DIP switches in the cable room. For the flow calculation, user-friendly and simple software is available to download free of charge from the systec Controls website (www.systec-controls.de). Using the F012 supply display unit, it is very easy to take a measurement including totalizer. The display unit that is connected to the mains powers either the deltaflowC probe or venturi with no additional cabling.

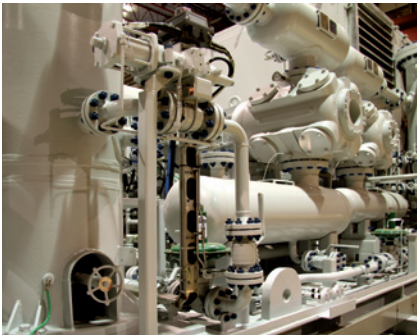
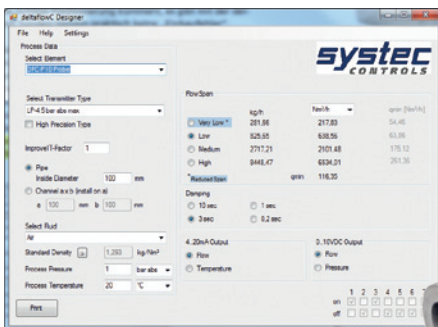

deltaflowC

The advantages at a glance

- The probe only requires a stud on the pipe. With the venturi, a pipe section is screwed in and connected via a cable to the transducer; that's all there is to it!
- deltaflowC computes the pressure and temperature and directly outputs the mass flow signal
- deltaflowC additionally provides output for temperature or pressure
- External pressure and temperature sensors are not required
- An external flowcomputer is superfluous
- Complex compensation processing is not required
- Simple parameterization and set-up
- Very good value for money
- Adaption to OEM requirements

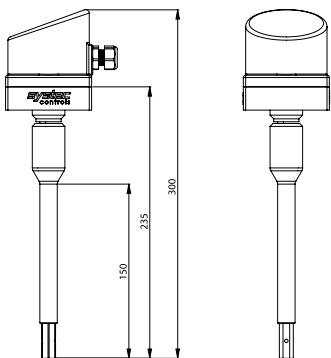
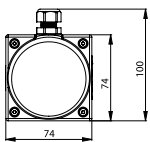

The compact venturi with connections G3/4, G1, G1 1/2 external thread also offers outstanding measurements for small flow rates.

Technical data

Description	Specification
Measurement principle	Differential-pressure with pressure and temperature compensation
Measured quantities	Mass flow, static pressure, temperature
Media	Gases, non-explosive/corrosive

Accuracy *	Standard Type	High Accuracy Type (calibrated)
	Standard type: 4% of measured value from 10% of the low-flow metering range	4% from 7% of the low-flow metering range

Variants	Probe	Venturi
Process connection	15 mm weld-in cut-ring stud (C- / SS-steel)	G3/4, G1, G1 1/2, external thread in acc. with DIN ISO 228-1
Housing & probe material	1.4571 Stainless steel	Aluminium
Pipe sizes	DN20 to ∞	-
Maximum insertion length	Typically to end stop, max 100 mm	-

Operating conditions	Min	Typical	Max	Unit
Pressure range LP	0 (Vacuum)	-	4,5	bar abs
Pressure range HP	0 (Vacuum)	-	14	bar abs
Medium temperature	-80	-	250	°C
Ambient temperature	-40	-	120	°C
Measurement range	1:25 (4 measurement ranges); 1:7 (at one measurement range)			
Bursting pressure			16	bar abs

Electrical specification	
Connections	GND Ground connection
Connection max. 1.5 mm ²	24 VDC Power supply
	0 - 10 VDC Output voltage signal
	4 - 20 mA Output current signal

	Min	Typical	Max	Unit
Voltage	18	24	36	VDC
Current	22	40	55	mA

Parameterized outputs	
Temperature output	-50 (4 mA) - 250 (20 mA) °C
Absolute pressure output	0,5 (0V) - 10 (10 VDC) bar abs

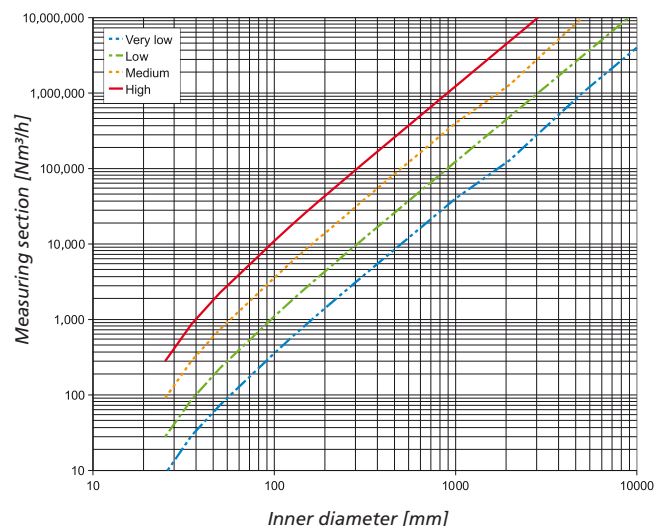
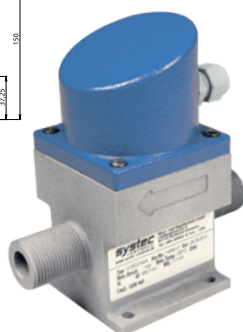
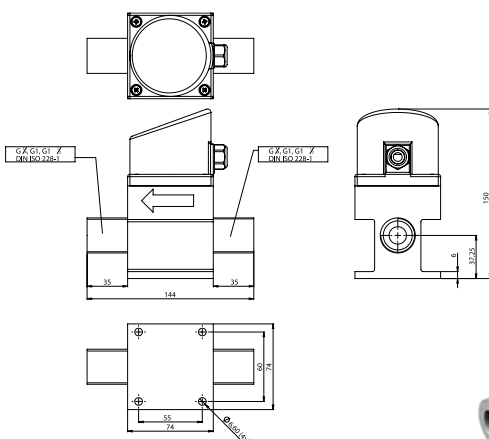

Flow metering technology “by systec”



deltawaveC-P clamp-on flowmeter for measuring liquids in filled pipes

The flowmeter with heat quantity metering operates according to the ultrasonic transit time method and is a high-precision device. The ultrasonic transducers can be quickly and easily clamped onto the pipe externally. It is not necessary to separate the pipes and there is no process stoppage. After simple parameterization, measurement of, for example, drinking water, wastewater, heating and cooling water, crude, light and thermal oils is leak-proof, pressure-resistant and wear-free. Together with the optionally available clamp-on temperature sensors, thermal energy can be recorded and documented reliably.

deltaflow for flow metering of gas, steam and liquids

The deltaflow pitot tube has proven its effectiveness a thousand times over for measuring the flow of gas, steam and liquids in pipes. Pitot tubes induce the lowest pressure loss of all differential pressure elements, which means that many applications can be used to make energy savings of several thousand euros per year. With an accuracy of up to 0.4% of the measured value as tested by the Physikalisch-Technische Bundesanstalt (PTB), the deltaflow probe can also be reliably used in the most adverse conditions.

deltaflow is extremely robust and its suitability is TÜV (German Technical Inspection Agency) tested for use in condensing, aggressive and dirty flue gases. deltaflow is available for pipe diameters from 1 mm – 15 m and a pressure level of up to 690 bar and can thus be used for the vast majority of flow applications.

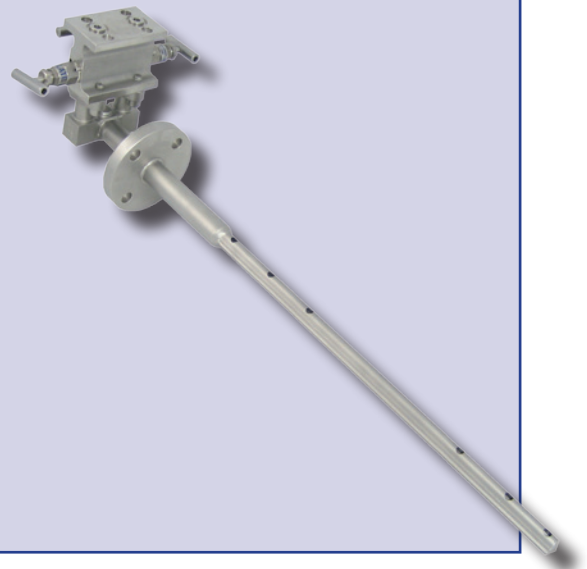

The head office of systec Controls is located in Puchheim, near Munich. Here, we develop and manufacture our products according to DIN EN ISO 9001. But innovation and product quality alone are not enough for us. We have also had our systems tested by independent institutes – with clear,

proven success. And of course, we are there for you even after the installation of your system. Our service-crew will assist you at your plant. systec Controls – the specialist in flow measurement technology.

Presented by:

systec
CONTROLS

Mess- und Regeltechnik GmbH
Lindberghstraße 4
82178 Puchheim
Germany
Phone: ++49 89 / 8 09 06 - 0
Fax: ++49 89 / 8 09 06 - 2 00
info@systec-controls.de

systec Controls
++49 89 / 809 060

www.systec-controls.de